

Frontier Telenet
Board of Directors
Meeting Minutes
FY2017

FRONTIER TELENET
BOARD OF DIRECTORS MEETING

JULY 21, 2017

MINUTES

The regular meeting of the Frontier TeleNet Board of Directors Meeting was called to order by Judge Steve Shaffer at 10:06 AM. This meeting held in the Courtroom of the Gilliam County Courthouse in Condon, Oregon.

Board of Directors Present: Judge Steve Shaffer, Judge Gary Thompson and Judge Lynn Morley

Also Present: Todd Cox and Steve Wynn, Day Wireless Systems, Mac Stinchfield, Times- Journal Newspaper, Kathryn Greiner, City of Condon, Rachel Weinstein, Giliam County Community Development, Will Carey, Legal Counsel, Elizabeth Farrar, Rob Myers, Mike Smith and Jeanne Burch.

Directors' Changes or Additions to Agenda: None

Minutes: Minutes for June 16, 2017 and June 29, 2017 (Special Meeting) reviewed by Directors. Steve Shaffer noted his name is misspelled once in the June 29, 2017 minutes. Moved by Lynn Morley, seconded by Gary Thompson to approve minutes of June 16, 2017 and June 29, 2017 minutes with correction. Motion carried with all present voting aye.

Financials: June Financial Statement reviewed. Mike Smith discussed pricing structure and bandwidth expense. Mike Smith and Rob Myers will be meeting to review contracts and pricing. Moved by Gary Thompson, seconded by Lynn Morley to approve June Financial Statement as presented. Motion carried with all present voting aye.

Resignation of Jeanne Burch: Jeanne Burch stated she is still very concerned about liability insurance for contracted services. Steve Shaffer has been trying to reach City County Insurance about this issue and will contact agent, John Anderson of Wheatland Insurance. This item tabled until information is received.

Review of Existing Contracts, Contractors and Duties of Contractors. A lengthy discussion held on contracting goals and what is needed in the contract renewals. It was agreed that marketing is very important. A question had been raised by outside entities if the \$52,000.00 in additional revenue has been achieved by marketing director. The following was reported: Burns Tribe an additional \$60,000.00. \$265,000.00 from the State of Oregon for the digital switch. Presently negotiating e-rate renewal and Harney and Lake Counties are in negotiation for services. Goals of \$52,000.00 met as over \$325,000.00 have been brought in as of now.

Letter from Les Ruark: Mr. Ruark requested the following letter be read into the record:

For the Record.

20 July 2017

Steve Shaffer, Chair

Frontier TeleNet Board of Directors

Condon, Oregon

Steve:

For the record, I respectfully request there be no final action taken Friday by Frontier TeleNet's board on agenda items 7, 8, definitely 17, and 18 (the latter item pending the specifics to be determined of the proposed AOC assessment and its resulting MOU).

To move forward on either of these significant and substantive matters (certainly and especially items 7 and 17) without first having provided the record-building agenda support material for each (of which none has been readily made available to date, that I'm aware of), and in turn providing a fair and truly meaningful opportunity for interested persons (aka the public) to access

this record and subsequently weigh in on it, would be to unduly, purposefully, and unnecessarily,

leave meaningful solicitation and serious consideration of public comment by the wayside.

With regard to the AOC proposal to conduct an assessment of Frontier TeleNet's past and current

work, and facilitate the forging of a Memorandum of Understanding (MOU) reflecting how to proceed with the results of that assessment, as I've previously indicated, I certainly support putting this collective effort in place and as quickly as possible.

Nonetheless, as I'm viewing the effort as it stands today, there should not be formal action taken

Friday in this matter—if that's what's contemplated—until such a proposed agreement has actually been committed to writing and disseminated to all interested parties, with adequate opportunity afforded them to react to and comment on it, and, that comment is then seriously considered at a subsequent board meeting.

To my knowledge, all that's been referred to date, as a proposed agreement, is an informal outline of the major elements of what could be involved, that's been shared by AOC with (essentially) a limited number of the interested parties involved. There's been no definitive proposed agreement (an AOC "contract" as the agenda refers to this matter) placed on the table

Friday that I'm aware of—as had been anticipated, or at least as I understood would occur.

Frankly, it's surprising and disappointing there's been no agenda support material prepared by now for Friday's meeting, reflecting the serious attempt that's needed here to proceed with arriving at an agreement that puts in place the assessment and MOU.

Preparation of such "asm" could likely have precluded the need there now is for having to have yet another meeting to achieve the appropriate and needed steps to get this effort underway.

Whatever, it is what it is.

Please have this comment incorporated into the record of the board's meeting Friday. Since I will

be working wheat harvest operations, I'm unable to attend Friday's meeting.

Thank you.

Sincerely,

Les Ruark

leswruark@gmail.com

(541) 454-2511

Director Lynn Morley objected strongly to this letter and requirements and stated that Frontier TeleNet must go on with their business.

Moved by Lynn Morley, seconded by Gary Thompson to approve contracts with Connections LLC and Jeanne E Burch. Jeanne Burch stated her renewal would be contingent on solving insurance questions. Motion carried with all present voting aye.

Update on Frontier TeleNet/Frontier Digital Network Merger. Legal Counsel Will Carey reported on how the merger of Frontier TeleNet/Frontier Digital Network will take place. Will Carey recommended that Frontier Digital Network be terminated. Each County will need to pass an ordinance and all Frontier Digital Network assets will go to Frontier TeleNet. After

ordinances are passed by each county, a copy of these ordinances needs to be filed with the Oregon Secretary of State within thirty days. All entities that Frontier Digital Network has contracts with will need to be notified.

Cottonwood Tower Update: Mike Smith reported this project is going very well. A land use permit has been approved and tower height has been solved with additional money becoming available. A cell phone company is showing interest in locating on the tower. Signed contracts will be coming soon.

Wheeler County Wireless Project Update: Mike Smith reported the State of Oregon has approved the changes to the Wheeler County Wireless Project. Wheeler County has interim financing in place and Lynn Morley and Mike Smith toured the County and progress coming along very well.

Light Speed Network (LSN)

Request for Arlington-Slatt Usage: Mike Smith gave an update of the needs for Arlington Slatt site and needs of Mr. Krebs and Arlington Co-Op TV. Will Carey will look at lease. Mike Smith stated he is opening conversations with other providers in the Mid-Columbia area. Day Wireless sees no problems with drawings submitted on LSN needs. CJIS (Criminal Justice Information Service) security issues discussed and Mike Smith suggested background checks for technicians are essential. Moved by Lynn Morley, seconded by Gary Thompson to approve co-location at Arlington Slatt location pending approval of legal counsel and landowner. Motion carried with all present voting aye.

Association of Oregon Counties (AOC) Assistance Contract: The Directors agreed that the quote for AOC Assistance at \$17,000.00 was too high for a small organization. Steve Shaffer will discuss with AOC to see if there can be a lower rate.

Website and Other Social Media and/or present public needs: Mike Smith is pursuing this project and will bring quotes back to Board.

SUAll Motorola Service Contract: This item discussed in Frontier Digital Meeting.

Sherman County Fiber Optic RFP for Wasco to Rufus: It was announced that funding is now available. Moved by Steve Shaffer, seconded by Lynn Morley to send out RFP for Wasco to Rufus Build with the approval of legal counsel. Advertising to be done in Times-Journal, East Oregonian and The Dalles Chronicle. Motion carried with all present voting aye. Mac Stinchfield informed directors that every legal ad in smaller papers goes to a Statewide Network.

Frontier 911 Burns Tribe Contract Request for Frontier TeleNet and alternative options for connections: Mike Smith reported that just a few changes to the contract have been made and Frontier Regional 911 has signed and sent to the Burns Tribe. Once the contract is signed, by both parties, the project must be done within 90 days. A discussion held on adding

their agencies. It was suggested that Frontier TeleNet talk to Harney County and see if Burns Tribe could co-locate equipment at the Harney County Courthouse. Moved by Lynn Morley, seconded by Gary Thompson to approve the Frontier 911 Contract with the alternative option of connection to Motorola Solution. Motion carried with all present voting aye.

Discussion/Possible Vote and Approval of Compensation Increases: Moved by Steve Shaffer, seconded by Gary Thompson to approve \$40.00 per hour for Rob Myers as part of the transition from Rob Myers to Mike Smith. Motion carried with all present voting aye. Moved by Gary Thompson, seconded by Lynn Morley to increase Mike Smith to \$6,750.00 per month and Jeanne E. Burch to \$1,800.00 per month. Motion carried with all present voting aye.

Audit Engagement Letter: Moved by Lynn Morley, seconded by Gary Thompson to approve the audit contract and engagement letter from Oster Professional Services for the fiscal year 2016-2017. Motion carried with all present voting aye.

Other Items: Mike Smith asked for direction if maintenance needs to be done. Moved by Lynn Morley to approve up to \$5,000.00 maintenance needs without prior authorization. Maintenance needs between \$5,000.00 to \$10,000.00 need Board Chairman approval. Motion carried with all present voting aye.

Gary Thompson requested that Mike Smith consult with Sherman County Commissioners McCoy and Dabulskis regarding Frontier TeleNet issues. Steve Shaffer also stated that Frontier TeleNet is the last mile organization and not a middle mile organization. Steve Shaffer also stated he is working with Zayo and other entities in the area regarding connectivity.

Will Carey suggested a Commissioner Orientation for all three counties would be a good idea so that Commissioners can understand what Frontier TeleNet does.

A discussion held about cities in the three counties having a seat on the Frontier TeleNet Board.

Steve Shaffer stated he feels we are not doing a good job of getting information out about who Frontier TeleNet is and what they do.

Public Input/Comment: None

Next Meeting: August 18, 2017 at 10 AM in Sherman County.

There being no further business the meeting adjourned at 12:45 P.M.

Respectfully Submitted:

Jeanne E. Burch,

Frontier TeleNet Staff

From: Les Ruark

Sent: Thursday, July 20, 2017 10:46 PM

To: Steve Shaffer; gthompson@co.sherman.or.us; Lynn Morley

Cc: Michael Smith; MichaelSmith204@gmail.com; Leanne Durfey; lhernandez@co.sherman.or.us; Snow Potter Brenda; cghumphreys@co.wheeler.or.us

Subject: Friday's FT meeting.

For the Record.

20 July 2017

Steve Shaffer, Chair
Frontier TeleNet Board of Directors
Condon, Oregon

Steve:

For the record, I respectfully request there be no final action taken Friday by Frontier TeleNet's board on agenda items 7, 8, definitely 17, and 18 (the latter item pending the specifics to be determined of the proposed AOC assessment and its resulting MOU).

To move forward on either of these significant and substantive matters (certainly and especially items 7 and 17) without first having provided the record-building agenda support material for each (of which none has been readily made available to date, that I'm aware of), and in turn providing a fair and truly meaningful opportunity for interested persons (aka the public) to access this record and subsequently weigh in on it, would be to unduly, purposefully, and unnecessarily, leave meaningful solicitation and serious consideration of public comment by the wayside.

With regard to the AOC proposal to conduct an assessment of Frontier TeleNet's past and current work, and facilitate the forging of a Memorandum of Understanding (MOU) reflecting how to proceed with the results of that assessment, as I've previously indicated, I certainly support putting this collective effort in place and as quickly as possible.

Nonetheless, as I'm viewing the effort as it stands today, there should not be formal action taken Friday in this matter—if that's what's contemplated—until such a proposed agreement has actually been committed to writing and disseminated to all interested parties, with adequate opportunity afforded them to react to and comment on it, and, that comment is then seriously considered at a subsequent board meeting.

To my knowledge, all that's been referred to to date, as a proposed agreement, is an informal outline of the major elements of what could be involved, that's been shared by AOC with (essentially) a limited number of the interested parties involved. There's been no definitive proposed agreement (an AOC "contract" as the agenda refers to this matter) placed on the table Friday that I'm aware of—as had been anticipated, or at least as I understood would occur.

Frankly, it's surprising and disappointing there's been no agenda support material prepared by now for Friday's meeting, reflecting the serious attempt that's needed here to proceed with arriving at an agreement that puts in place the assessment and MOU.

Preparation of such "asm" could likely have precluded the need there now is for having to have yet another meeting to achieve the appropriate and needed steps to get this effort underway. Whatever, it is what it is.

Please have this comment incorporated into the record of the board's meeting Friday. Since I will be working wheat harvest operations, I'm unable to attend Friday's meeting.

Thank you.

Sincerely,

Les Ruark

leswruark@gmail.com

(541) 454-2511

Leif,

I presented your request to the Board. They have several questions for me and you to answer and asked me to move forward. They will be meeting in Condon on June 2nd at 10:00.

Here is what they are asking for.

- Work through the agreement with Counsel. You have a drafted agreement. Will Carey was at the meeting and understands we need to move this forward.

Neither Cassandra nor I have heard from Will on this.

- The Board asked for a diagram of the work you are asking to perform. It doesn't have to be engineered documents, just a drawing of the work that you are wanting to do so they can get a better understanding of your goals.

Attached. We are looking to bring a new 4" conduit into the building to facilitate a new fiber cable. The best way we have found to bring in new conduit to an existing building is to attached the conduit onto the outer wall, through a sealed junction box at the height where the fiber can drop directly onto the overhead racking. This is what we have proposed. Construction method for the new duct across the Frontier lease area would be open trench at a depth of 36".

- I need to go through our lease and make certain the work you are doing does not cause any issues with our relationship with the land owner. They are very particular about added equipment. Once I have a drawing of the work to be done I can get through that portion.

We have been in contact with Mr. Krebs for some time and have a workable agreement with him to allow the new installation across his property. All he would require from you is a letter of authorization.

- The Board did ask if the technicians you have are CJIS certified. They are working towards having anyone entering shelters of this importance to have a thorough screening and training due to the mission critical nature of the site. With the work you do for the Courts I imagine you do, but could not verify that fact.

All of our field staff are required to undergo background checks and drug screens. This allows us to be authorized into other secure state and central office facilities around the state. We do not have CJIS certification but believe our current protocol offer similar protection.

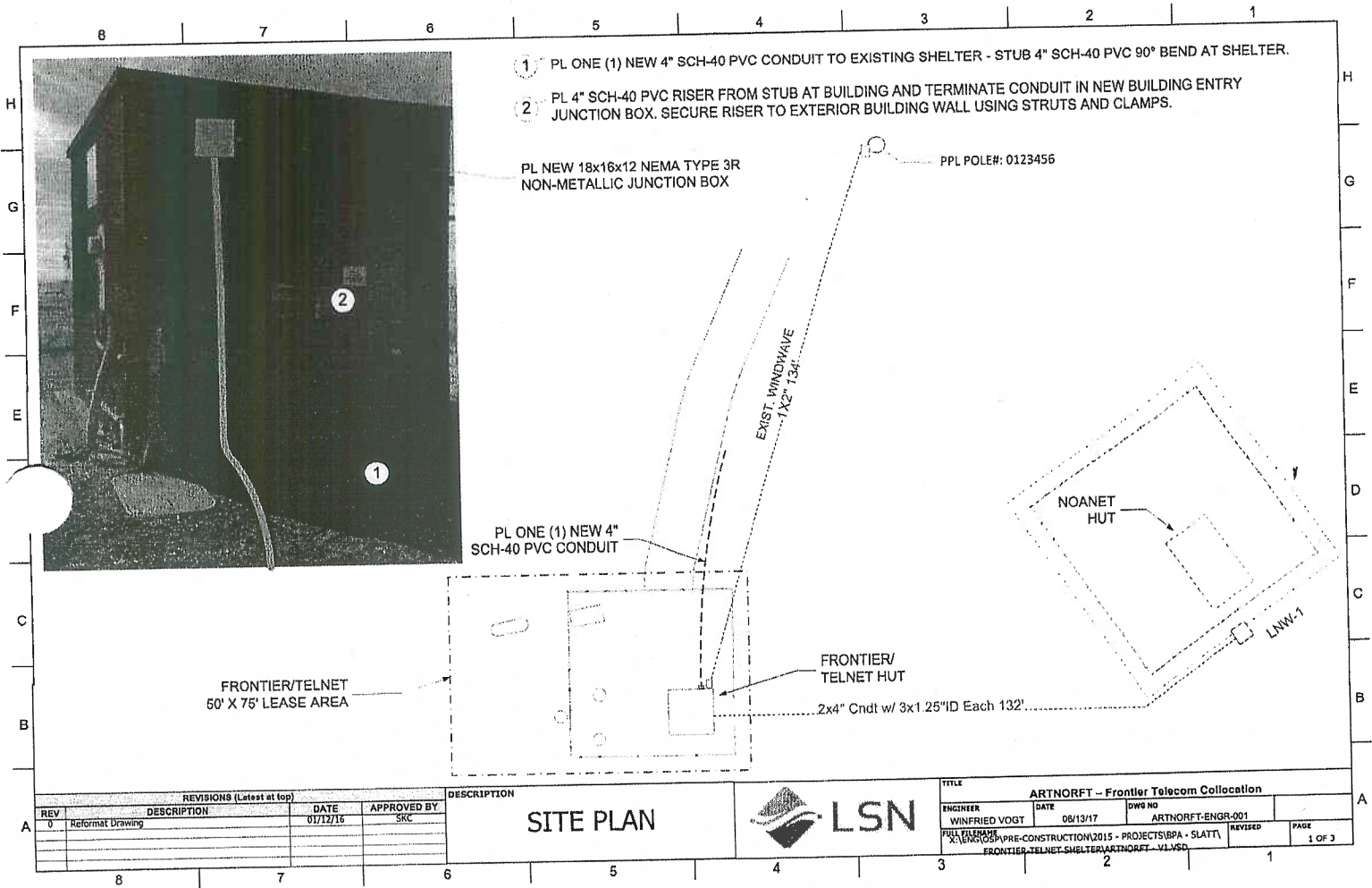

- ① PL ONE (1) NEW 4" SCH-40 PVC CONDUIT TO EXISTING SHELTER - STUB 4" SCH-40 PVC 90° BEND AT SHELTER.
- ② PL 4" SCH-40 PVC RISER FROM STUB AT BUILDING AND TERMINATE CONDUIT IN NEW BUILDING ENTRY JUNCTION BOX. SECURE RISER TO EXTERIOR BUILDING WALL USING STRUTS AND CLAMPS.

PL NEW 18x16x12 NEMA TYPE 3R NON-METALLIC JUNCTION BOX

PPL POLE#: 0123456

PL ONE (1) NEW 4" SCH-40 PVC CONDUIT

EXIST. WINDWAVE
1X2" 134"

NOANET HUT

FRONTIER/TELNET
50' X 75' LEASE AREA

FRONTIER/
TELNET HUT

2x4" Cndt w/ 3x1 25"ID Each 132'

LNN-1

REVISIONS (Latest at top)			
REV	DESCRIPTION	DATE	APPROVED BY
0	Reformat Drawing	01/12/16	SKC

DESCRIPTION
SITE PLAN



TITLE ARTNORFT - Frontier Telecom Collocation			
ENGINEER	DATE	DWG NO	
WINFRIED VOGT	06/13/17	ARTNORFT-ENGR-001	
FULL RELEASE		PRE-CONSTRUCTION/2015 - PROJECTS/BPA - SLATT	REVISED
X-RELEASE		FRONTIER TELNET SHELTER/ARTNORFT - VL VSD	PAGE 1 OF 3

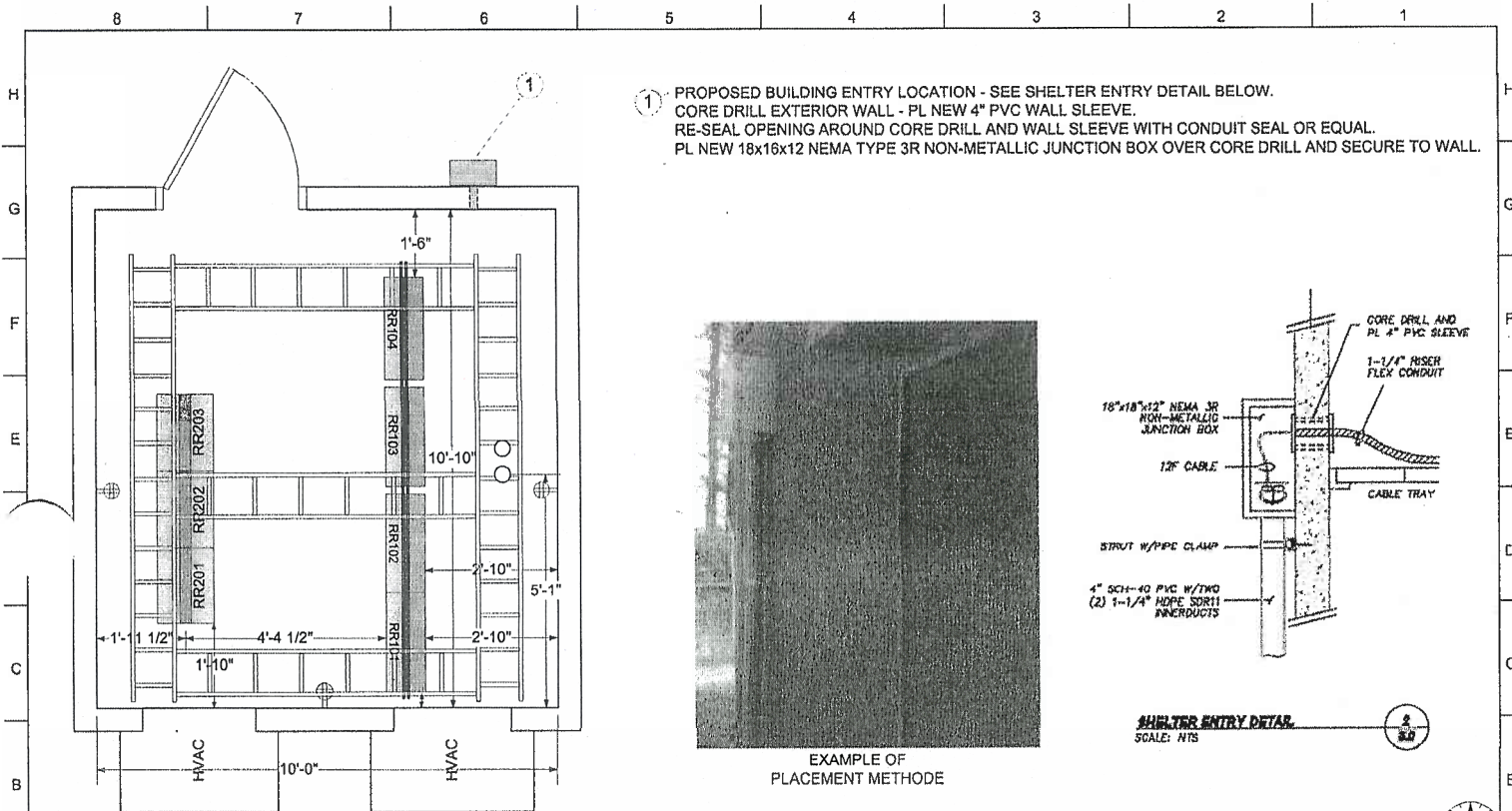

① PROPOSED BUILDING ENTRY LOCATION - SEE SHELTER ENTRY DETAIL BELOW.
 CORE DRILL EXTERIOR WALL - PL NEW 4" PVC WALL SLEEVE.
 RE-SEAL OPENING AROUND CORE DRILL AND WALL SLEEVE WITH CONDUIT SEAL OR EQUAL.
 PL NEW 18x16x12 NEMA TYPE 3R NON-METALLIC JUNCTION BOX OVER CORE DRILL AND SECURE TO WALL.

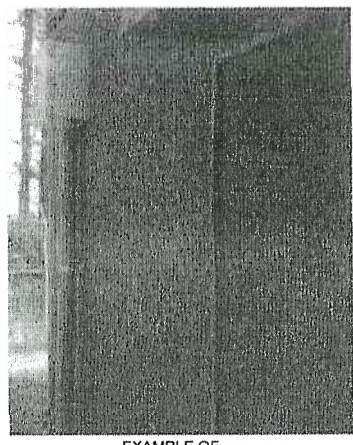

EXAMPLE OF
 PLACEMENT METHODE

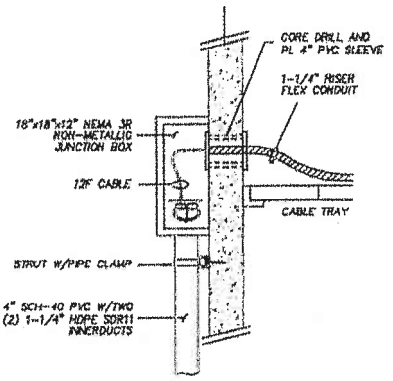

SHELTER ENTRY DETAIL
 SCALE: NTS



REVISIONS (Latest at top)			
REV	DESCRIPTION	DATE	APPROVED BY
0	Reformat Drawing	01/12/16	SKC

DESCRIPTION
SHELTER PLAN



TITLE				
ENGINEER	DATE	DWG NO	PROJECT	
WINFRIED VOGT	08/12/17	ARTNORFT-ENGR-001	ARTNORFT - Frontier Telecom Collocation	
FULL DRAWING		X:ENG(05)PRE-CONSTRUCTION\2015 - PROJECTS\BPA - SLATT\		REVISION
FRONTIER TELNET SHELTER\ARTNORFT - V1.VSD				PAGE
				2 OF 3

A

FRONTIER TELENET
BOARD OF DIRECTORS MEETING
MINUTES

AUGUST 25, 2017

The regular meeting of the Frontier TeleNet Board of Directors was called to order at 10:15 by Chairman Judge Steve Shaffer. This meeting held at the Wasco Annex in Wasco, Oregon.

Directors Present: Steve Shaffer, Lynn Morley and Gary Thompson

Also Present: Ryan LeBlanc, Steve Wynn, Tom McCoy, Mac Stinchfield, Kathryn Greiner, Elizabeth Farrar, Will Carey, Jack Lyon, Matthew Sechora, Mike Smith, Jeanne Burch and Rob Myers (by telephone).

Public Input/Comment: Jack Lyon addressed the meeting and asked what the benefits are for the broadband consumer and what is available and how it is accessed. Directors explained that Frontier Telenet provides service to the community but the local ISP is who provides to the individual consumer.

Directors Changes or Additions to Agenda: Personal Services Contracts for 2017-2018.

Minutes: Minutes of July 21, 2017 Frontier TeleNet Board of Directors Meeting reviewed. Moved by Lynn Morley, seconded by Gary Thompson to approve the minutes as presented. Motion carried with all present voting aye.

Financials: Financial Statement for July presented. Steve Shaffer was interested in how much we pay each month for Broadband Service from the individual carriers. Each carrier is noted on the financial statement and the amount paid. Tom McCoy asked if a marketing plan is being developed and feels that is a necessity. Mike Smith agreed and said that a marketing plan has been developed and reminded Commissioner McCoy that this had been presented to the Sherman County Court several months ago. Moved by Gary Thompson, seconded by Lynn Morley to approve financial statement as presented. Motion carried with all present voting aye.

Frontier Digital Network/Frontier TeleNet Merger: All three counties have passed the necessary ordinance to create the FDN/FTN Merger and this will be taken care of at the September 15, 2017 regular meeting.

Cottonwood Tower Update: This was a Frontier Digital Network Meeting item.

Wheeler County Wireless Project Update: Governor Brown has signed the necessary documents and project is proceeding. The first phase is to deal with the wireless project in Fossil and there already is 30% more bandwidth.

AOC Assistance Update: Greg Wolf of Association of Oregon Counties is working on this project. Greg has done 7 or 8 interviews and will be doing more in September 2017. There also was a discussion of having a booth at the AOC December Conference and possibly sharing with CORREA.

Web Site and other Social Media Presentation: Matt Sekora of Sekora Consulting and IT Solutions presented bids for the Frontier TeleNet Request to establish a web site. Bids were Sekora Consulting \$\$4500.00 plus \$190.00 Web Hosting Fee for a total of \$4,690.00. IT Solutions \$5,200.00 plus \$79.00 per month for Web Hosting. Moved by Lynn Morley, seconded by Gary Thompson to retain Sekora Consulting to construct the Frontier Telenet Web Site with a cap on contract to be \$4,800.00. Motion carried with all present voting aye.

SUAll Motorola Service Contract Proposal: This was a Frontier Digital Network Item.

Sherman County Fiber Optic RFP for Wasco to Rufus Update: Mike Smith reported the tentative date to advertise this RFP is September 15, 2017 but will not advertise until guarantee that funds are available. It was the consensus of Directors to authorize advertising this RFP at the appropriate time.

Frontier 911-Burns Tribe Update: Waiting for a signed contract to come back from Chief Smith. There will be a new CEO for the Burns Tribe and that may be holding up receiving the signed contract.

Indemnification of Contractors: This was taken care of in the Frontier Digital Network meeting.

Personal Services Contract Renewal: Moved by Lynn Morley, seconded by Gary Thompson to approve the renewal of Personal Services Contracts for Jeanne E. Burch and Michael Smith dba Connections LLC and approve contract with Rob Myers dba R.E. Myers and Associates for \$40.00 per hour to be billed monthly. Motion carried with all present voting aye.

Receipt of New Policies and Procedures Documents: Legal Counsel Will Carey stated this is for procurement and the rules are regularly updated. To adopt there needs to be a public hearing and also needs to be advertised. These documents will be taken care of at September 15, 2017 Board of Directors Meeting.

Resolution No. 082517-001 a Policy for expense spending: Resolution No. 082517-01, a Resolution Providing for spending limits for continuing maintenance and emergency issues with and without prior authorization reviewed. Moved by Lynn Morley, seconded by Gary Thompson to approve Resolution No. 082517-001 as presented. Motion carried with all present voting aye.

Policy for Records Request and Fee Structure. Mike Smith stated that Directors have had this draft policy and that a cost for electronic requests has been added. Moved by Lynn Morley, seconded by Gary Thompson to approve the Policy for Records Request and Fee Structure as amended. Motion carried with all present voting aye.

Items for the good of the order: Steve Wynn or Day Wireless, praised the performance of the Frontier Telenet and Frontier Digital Network system during the Solar Eclipse. Steve said that it worked perfect and he was very pleased.

Public Input/Comments: Jack Lyon stated that he is still concerned about individual service to private homes and businesses. Kathryn Greiner asked about the Pinnacle Debt and would it be transferred to Frontier TeleNet when the merger of the two entities occurs. Judge Shaffer answered yes and informed that there are still two years left on this debt. Judge Shaffer also stated that he is not a complete believer that fiber to the home is going to be the future and wireless is more in demand.

Next Meeting: September 15, 2017 in Fossil. Frontier Digital will begin at 9:50 AM and Frontier Telenet at 10 AM. The Public Hearing on Policies and Procedures will be advertised for 10:15 AM.

There being no further business the meeting adjourned at 12:22 PM.

Respectfully Submitted:

Jeanne E. Burch

Frontier TeleNet Staff.

FRONTIER TELENET
BOARD OF DIRECTORS MEETING
MINUTES

SEPTEMBER 15, 2017

The regular meeting of the Board of Directors of Frontier TeleNet was called to order by Chairman Judge Steve Shaffer at 10:10 AM.

Directors Present: Judge Steve Shaffer, Judge Gary Thompson and Judge N. Lynn Morley.

Also present: Todd Cox and Ryan LeBlanc, Day Wireless System, Will Carey, Legal Counsel, Ron Spencer, Motorola, Rob Myers, Pat Shaw, Tom Wolf, Columbia Basin Electric Co-op, Mac Stinchfield, Times Journal, Jack Lyon, Lori Anderson, Rob Ordway, Wheeler County Commissioner, Mike Smith and Jeanne Burch, Frontier TeleNet Staff.

Public Input-None

Directors Changes or Additions to Agenda: None

Minutes: Minutes of August 25, 2017 Board of Directors Meeting reviewed. Two corrections were noted. The spelling of CREA and the Statement by Tom McCoy regarding Inland Development Corporation payments from Sherman County removed. Moved by Lynn Morley, seconded by Gary Thompson to approve the August 25, 2017 Board of Directors Meeting as corrected. Motion carried with all present voting aye.

Financial: Financial Statement for August 2017 reviewed. Moved by Gary Thompson, seconded by Lynn Morley to approve August 2017 financial statement as presented. Motion carried with all present voting aye.

Public Hearing: A public hearing was called to order at 10:15. The purpose of this hearing is to receive comment on proposed Public Contracting Rules for Frontier TeleNet. Legal Counsel Will Carey explained that the Frontier TeleNet could adopt their own special Public Contracting Rules. By adopting these rules an entity is exempt from following the Attorney General Rules. Will Carey also stated that the law firm of Hoyt Speer, who prepared the rules, specializes in public contracting rules. The proposed rules give the Board some discretion and also allows the Frontier TeleNet Board to become the Public Contracting Review Board. Judge Pat Shaw spoke in favor of this Resolution and stated it makes it much easier to have these in place plus access to a law firm that keeps up to date on the rules. Mike Smith has been asked to send a copy of these rules by email to an interested person.

Hearing Closed at 10:20 AM.

Frontier TeleNet meeting resumed at 10:21 AM.

Public Contracting Rules: Moved by Gary Thompson, seconded by Lynn Morley to adopt Public Contracting Rules Resolution No. 9152017-01 and to adopt the findings in Exhibit A of this document. Motion carried with all present voting aye.

Moved by Lynn Morley, seconded by Gary Thompson to adopt a resolution no. 9152017-02, a Joint Resolution of the Board of Directors and Local Contract Review Board opting out of the Attorney General's Model Public Contracting Rules and amending public contracting rules for Frontier TeleNet. Motion carried with all present voting aye.

Cottonwood Tower Update: Mike Smith reported that there is continued progress on this project. Regarding the radio frequencies, Ryan LeBlanc reported that the plan has been approved and that it needs to be approved by Region 43 which will meet on September 26, 2017. Ryan explained that the Cottonwood project is just on the edge of Region 43 but he sees no problem with the approval. With the radio frequencies being approved in the next two weeks, the radio order at Motorola can start to be built.

Wheeler County Wireless Project: in Lynn Morley reported that he is working out the final details on this project. Governor's approval and signature have been obtained and also approved by the Wheeler County Court. It was noted by others in the room that this is a model project for a wireless system.

AOC Assistance Contract: Greg Wolf has met with several people regarding Frontier TeleNet and will conduct a few more to interview. Greg will have a report in the next few weeks. Greg suggested an audit of Frontier TeleNet Equipment might be helpful. Reaching out to mission-critical partners to discuss costs.

Website Update: Mike Smith reported he had talked to Matt Sekora and project is being worked on.

SUAll Motorola Service Contract: Mike Smith reported the original cost of service contract was \$360,000.00 and it has been negotiated down to \$200,000.00 for the first year and \$230,000.00 for subsequent years. A discussion held on where the funds to pay this contract will come from. Mike Smith reported he is working with an entity that might be interested in connecting to FTN Digital Switch as this saves them considerable money. Moved by Lynn Morley, seconded by Gary Thompson to approve System Upgrade with Motorola with a revised cost of \$200,000.00 for the first year and \$230,000.00 for subsequent years. The first payment on this agreement will be in July 2018. Motion carried with all present voting aye.

Sherman County Fiber Optic RFP, Wasco to Rufus Update: An RFP has not been advertised as legal counsel Jim Deason had expressed some concerns. Mr. Deason is working with Will Carey on these concerns. Centurylink is now showing some interest in this project. Mike Smith reported this project has been approved and Frontier TeleNet is just waiting for the funds from the State of Oregon to proceed.,

Frontier 911-Burns Tribe Update: Still waiting for a signature on documents. Burns Tribe has a new executive officer and that is why it has taken some time for documents to be signed.

Other Items for the good of the Order: Steve Shaffer reported on a meeting with Gilliam County, the City of Condon, Columbia Basin Electric, Joe Franell and City of Condon Consultant regarding the fiber build with Zayo Bandwidth. Steve stated they did not want Frontier TeleNet at the table.

Ron Spencer representing Motorola presented Rob Myers with a plaque expressing Motorola's appreciation of the years Rob has invested in Frontier TeleNet and Frontier Digital Network as General Manager.

Public Input/Comment: None

Next Meeting: October 20, 2017 at the Gilliam County Courthouse in Condon, Oregon at 10 AM

There being no further business the meeting adjourned at 11:10 AM.

Respectfully Submitted:

Jeanne E. Burch

Frontier TeleNet Staff

FRONTIER TELENET
BOARD OF DIRECTORS MEETING
OCTOBER 20, 2017
MINUTES

The Regular meeting of Frontier TeleNet Board of Directors was called to order by Chairman, Judge Steve Shaffer at 10:03 AM. This meeting held in the Lower Conference Room of the Gilliam County Courthouse in Condon, Oregon.

Directors Present: Judge Steve Shaffer, Judge Gary Thompson and Judge N. Lynn Morley.

Also Present: Ryan LeBlanc, Steve Wynn and Todd Cox of Day Wireless System, Will Carey, Legal Counsel, Rob Myers, Mac Stinchfield, Times- Journal Newspaper, Lori Anderson, Columbia Basin Electric, Rob Myers, Mike Smith and Jeanne Burch, Frontier TeleNet.

Public Input/Comment-None

Directors' Changes or Additions to Agenda: None

Minutes: A correction was noted in the spelling of Ron Spencer's name is the September 15, 2017 minutes. Moved by Gary Thompson, seconded by Lynn Morley to approve September 15, 2017 meeting minutes as corrected. Motion carried with all present voting aye.

Financial Statement: Financial Statement for September 2017 reviewed by Directors. Moved by Lynn Morley, seconded by Gary Thompson to approve September 2017 Financial Statement as presented. Motion carried with all present voting aye.

Old Business:

Cottonwood Park Update: Mike Smith reported on the Cottonwood Park Tower Project. A permit is in place. Day Wireless is still waiting for Region 43 to send the license paper that has been approved. Motorola and waiting to start production and the project is within budget. The lease is in place and a cell phone company is showing some interest. Oregon State Parks is planning on breaking ground soon.

Day Wireless Contract with Frontier Digital Network and Frontier TeleNet. Day Wireless presented a new contract that takes into account the merger of Frontier Digital Network and Frontier TeleNet. Legal Counsel will review this document and it will be dealt with at the next meeting.

Wheeler County Wireless Project: Legal Counsel Will Carey clarified sections of the agreement between Wheeler County and Frontier TeleNet for the construction of the Wheeler County Wireless Project. Will Carey discussed Sections 3.2, A, B and C. There are certain requirements when funds may be disbursed. Language will be changed to agree with the State of Oregon

Grant to Wheeler County. Two changes need to be made, 3.2B stays as is, 3.2C is okay until the second line and needs to say County shall disburse to Frontier TeleNet. All disbursements are subject to the State of Oregon Department of Administrative Services Grant Agreement as described in Attachment A. Moved by Gary Thompson, seconded by Steve Shaffer to accept the Wheeler County Broadband Agreement with corrections. Motion carried with Steve Shaffer and Gary Thompson voting aye and Lynn Morley abstaining due to a conflict of interest. A discussion followed regarding the need to run a Supplemental Budget for Frontier TeleNet to accommodate the Two Million Dollars for this project. The consensus of Directors to authorize finance department to run the supplemental budget for Two Million.

AOC Assistance Update: Steve Shaffer had not met with Greg Wolf. He knows that Greg Wolf intended to meet with the founders of Frontier TeleNet and a report should be available for the November meeting.

Frontier TeleNet Website Update: Mike Smith reported he has met with Matt Sekora and the project is progressing. A detailed conversation was held regarding Frontier TeleNet email account and the preference of .com, .net, or .org. Consensus of Directors to have .com. Samples of a logo were handed out and the color choice will be red, white and blue. Also a one-page description of "What Is Frontier TeleNet" was given to the directors. All agreed that this is an important document, as quite often the public does not understand what this organization does.

Sherman County Fiber Optic RFP Wasco to Rufus Update: Mike Smith reported on meetings on this project and that Centurylink had attended, Centurylink stated they are updating their equipment. Mike is working with the State of Oregon on authorizing the funds for this project and is very optimistic.

Frontier 911 Burns Tribe Update: Steve Wynn reported that Day Wireless will be having a conference with Motorola on this project and will have a contract to sign. This contract will be brought back to the Board. Steve Shaffer asked about the Harney County system and Todd Cox reported he has been attending meetings on this project.

Other Items for Good of the Order: Steve Shaffer reported on the Gilliam County Project and said that everyone is working together on the fiber-build project for the area.

Public Input/Comment-None

Next Meeting: November 3, 2017 at the Jeanne E. Burch Building in Fossil, Oregon at 10 AM.

There being no further business, the meeting adjourned at 11:35 AM.

Respectfully Submitted

Jeanne E. Burch, Staff.

Frontier TeleNet
Board Meeting
October 20, 2017
Sign In Sheet

Steve Wyma	Day Wireless
Ryan LeBlanc	Day Wireless
Todd Cox	Day Wireless
Rob Myers	FTN/FDN
Gary Thompson	Sheena @
Mike Smith	FTN
Lou Adams	CBAC
Mac Stuchfield	Times-Journal
Will Carey	

FRONTIER TELENET
BOARD OF DIRECTORS MEETING
MINUTES
NOVEMBER 3, 2017.

The regular meeting of the Frontier TeleNet Board of Directors Meeting was called to order by Vice-Chairman Judge N. Lynn Morley at 10 AM.

This meeting held in the conference room of the Jeanne E. Burch Building, 401 Adams Street, Fossil, Oregon.

Public Hearing: The regular meeting recessed and a Public Hearing was opened to hear public testimony on Supplemental Budget Resolution No. 110317-01. There was no public comment. This hearing closed at 10:04 AM.

Regular meeting resumed at 10:05 AM. Judge Steve Shaffer joined the meeting.

Directors Present: Judge Steve Shaffer, Judge Gary Thompson and Judge N. Lynn Morley.

Also Present: Steve Wynne, Day Wireless Systems, Kathryn Greiner, City of Condon, Mac Stinchfield, Times Journal Newspaper, Judge Pat Shaw, Mike Smith, Rob Myers and Jeanne Burch, Frontier TeleNet Staff.

Mike Smith announced that Legal Counsel Will Carey was on his way to attend this meeting when his car broke down.

Consideration of Supplemental Budget: Moved by Gary Thompson, seconded by Lynn Morley to approve Supplemental Budget Resolution No. 11-03-17-01 that establishes adding \$2,000,000.00 to Frontier TeleNet Resources and Requirements for the fiscal year 2017-2018 to manage the Wheeler County Broadband Project. Motion carried with all present voting aye.

Directors Changes or Additions to the Agenda: Steve Shaffer requested that a report on Frontier Regional 911 be added to the agenda.

Minutes: Moved by Lynn Morley, seconded by Gary Thompson to approve the October 20, 2017 Board of Directors Meeting Minutes as presented. Motion carried with all present voting aye.

Financial Review: Moved by Gary Thompson, seconded by Lynn Morley to direct Jeanne Burch to close the Frontier Digital Bank Account as all Frontier Digital assets have been transferred to Frontier TeleNet. Motion carried with all present voting aye.

Moved by Lynn Morley, seconded by Gary Thompson to approve October 2017 Financial Statement as presented. Motion carried with all present voting aye.

Day Wireless Frontier TeleNet/Frontier Digital Contract Merger: Mike Smith reported that Will Carey has a couple of things to change but has requested the Board of Directors approve the contract on approval of legal counsel. Moved by Steve Shaffer, seconded by Lynn Morley to approve Day Wireless revised contract on legal counsel approval. Motion carried with all present voting aye.

AOC Assistance Update: Steve Shaffer called Greg Wolf regarding this project but has not heard back. Final Report should be complete by December Board of Directors Meeting.

Frontier TeleNet Website Update: A lengthy discussion was held on the Frontier TeleNet Logo. Website development is moving forward and a prototype should be available by the next meeting.

Frontier Regional 911/Burns Tribe Update: Mike Smith reported the cost of this project is going to be less. The facility will now be at the Burns Paiute Tribal Location instead of the Harney County Courthouse and this has reduced the cost. The cost was roughly \$90,000.00 and will now be \$67,178.00. The Burns Paiute Tribe is paying \$60,000.00 for this cost. Steve Shaffer commented that Frontier TeleNet needs to work on the numbers for Harney County for utilization of Frontier TeleNet Infrastructure. The project will probably happen in phases.

Other Items for Good of the Order:

Frontier Regional 911 will be changing executive director, due to current executive director retirement. There could be an adjustment in structure with a Communication Supervisor and a Field Training Officer and additional duties of dispatchers. There have been some complaints about hand held devices in Sherman County. Steve Wynne has worked with the Fire Chiefs and Emergency Services Personnel about possible solutions.

Pinnacle Finance billing has been received and will be due in December. Each county will be billed their portion.

Mid Columbia Regional Solutions has talked to Steve Shaffer about a loop from the Maupin area. They have requested information from Regional Solutions to see if there might be a project for the whole Regional Solutions area. There are Four Million Dollars available for the whole Regional Solutions. There would be Two Hundred Thousand available for the Mid Columbia Regional Solutions and the project they have in mind would cost One Million Six Hundred Thousand Dollars. Gary Thompson asked if we should extend our digital switch to Maupin. Mike Smith said this is a good idea and it can be done. This project may be worked on in the future.

Mike Smith, Sheriff Laurey and Steve Wynn met with Fire Chiefs in Sherman County. This was a very productive meeting and the Fire Chiefs were appreciative of learning how the emergency

radio systems work. Connections with the Emergency Services of each County will be worked on by Mike Smith.

Public Input: Mac Stinchfield from the Times Journal Newspaper reported that he always welcomes public comment but he was disappointed in a recent letter to the editor in the Times Journal Newspaper. He stated that his information regarding the Sherman County Request for Proposal that was not advertised but given to potential contractors came from the Frontier TeleNet Minutes. He stated that as far as he knew, this RFP still does not have a legal review from Frontier TeleNet Legal Counsel. He stated that he still feels it is not right that this RFP has not been advertised but was given to potential bidders. He stated that his comment in the July Frontier TeleNet Minutes was the question if the Times Journal reaches enough people with an RFP advertisement. He stated that every legal advertisement goes to a statewide site when a paper belongs to the Oregon Publishers Association. In August 2017 minutes it was reported that an advertisement would go out by September 2017 but was noted that the funds were not yet available. Directors felt that the advertisement should go out at the appropriate time. In September there were two sets of minutes and Finance Clerk stated she could look those up for him on the computer. In those minutes it stated that RFP had not been advertised as legal counsels were working on them. Mac Stinchfield restated his concern, which was written in the editorial, was the RFP had not been advertised and yet it was handed out to potential bidders. He stated that was his concern, and still his concern. Mike Smith stated that he could answer these questions. Mike's statement was as follows. RFP was approved by legal counsel. Will Carey, Legal Counsel, approved RFP and RFQ. Jim Deason, the legal counsel, came on later and stated he would like to change a couple of items, after the fact. Mike also stated that there was a discussion of whether to advertise as a draft RFP/RFQ as Frontier TeleNet was still waiting for funds. Mike reported that he hoped everyone could work together.

Judge Pat Shaw: Made the following statement. Praising the progress that Frontier TeleNet has made. She also stated that regarding newspaper articles, that in all her years of ethics training, she had to ask herself. If not for my position, would I be doing what I am doing, or thinking the way I think. I need to stay upfront that I am not impartial. I have written two letters to the editor and stated that the meeting I attended did not seem like the meeting that was reported. What I am saying, is we all see things in a different light. I was wondering if it were not for a wife on the Condon City Council and the Condon Fiber Committee, would the editor be so intense on the reporting of Frontier TeleNet. What I am saying, if not for my previous position, would I have this interest in Frontier TeleNet, probably not. However, I do and I try really hard to see it from a nonparticipants viewpoint. We only have one newspaper in these communities, and when Joe Blow on the street reads what is suppose to be a news article and not an editorial. When I read a editorial I know that is the editor's opinion. When I read a news article, I feel it should be fact whether it is local, national or international. I have read many news articles that I felt had an editorial in them. That is why I wrote the letters, and why I am here today. I do not know why in these small communities these organizations cannot get together and get something done. We all work for the same people and it seems like if we

cooperate the common projects would get done and not have this public display of frustration with each other.

Steve Shaffer replied duly noted.

Kathryn Greiner asked if the Paiute Tribe Contract has been signed. Mike answered yes.

Kathryn Greiner stated she thought the Paiute Tribe was paying the whole cost of installation and asked if Frontier TeleNet was paying a portion. Steve Shaffer replied that because of the conversations that had gone on with Harney County, Frontier TeleNet decided to pay the extra \$7,000.00 to complete the system so Harney County could hook up also. Kathryn asked what the Paiute Tribe was paying for the service and also was the Day Wireless Contract going to be more, and if so how much? Mike Smith answered there would be an additional \$4,000.00 a year cost to Motorola but this will be paid by the Frontier Regional 911 portion of the Motorola Maintenance Agreement. This will be next year's budget. Kathryn Greiner asked does the tribe pay Frontier TeleNet or Frontier Regional. Mike Smith reported that the tribe is paying \$60,000.00 toward the cost of equipment, Frontier TeleNet is paying \$7,000.00 and Frontier Regional 911 is giving the tribe a special price for the first three years to accomplish getting the project to Frontier 911. Steve Shaffer suggested that Kathrine Greiner could probably have her questions answered by attending a Frontier 911 meeting.

Steve Wynne reported that sites were being visited and necessary repairs and upgrades were being accomplished. Also pleased with the meeting with the Fire Chiefs in Sherman County and working with emergency management in each county. Weeds are getting out of hand at site locations and Steve Shaffer requested that a spray program and weed eradication be taken care of by Mike Smith for next spring. Rob Myers also reported that the fence at the air base site needs to be replaced. Needs a quality fence due to livestock that is adjacent to the site.

Gary Thompson requested that the Board of Directors set down at a future meeting and work on a long-range plan for Frontier TeleNet. He feels that a five to ten-year long-range plan is needed. Steve Shaffer agreed as telecommunications is moving very rapidly.

Next Meeting will be December 15, 2017 in Moro, Oregon at the Steve Burnet Building at 10AM.





Frontier TeleNet

Sign in Sheet

Board Meeting

Fossil, Oregon

11-03-217 - 10 AM

Pat Shaw

Kalvin Turner

Mac Stuchjue

Rob Myers

Steve Wynne

Miki Smith

FRONTIER TELENET

MINUTES

JANUARY 19, 2018

The regular meeting of the Frontier TeleNet Board of Directors was called to order by Chairman Judge Steve Shaffer at 10AM. This meeting held in the Courtroom of the Gilliam County Courthouse, 221 Oregon Street, Condon, Oregon.

Directors Present: Judge Steve Shaffer, Judge Lynn Morley and Sherman County Commissioner, Tom McCoy representing Judge Gary Thompson.

Also Present: Ryan LeBlanc and Todd Cox, Day Wireless System. Mac Stinchfield Times-Journal Newspaper, Kathryn Greiner, City of Fossil, Rob Myers, Mike Smith and Jeanne Burch, Frontier TeleNet Consultants and Staff.

Directors Changes to Agenda: None

Minutes: Moved by Lynn Morley, seconded by Steve Shaffer to approve December 15, 2017 Directors Meeting Minutes as presented. Motion carried with all present voting aye.

Financial Statement: Moved by Lynn Morley, seconded by Steve Shaffer to approve December 15, 2017 Financial Statement as presented. Motion carried with all present voting aye.

Gilliam County RFP: Judge Shaffer provided an update on the Gilliam County Request for Proposal regarding fiber installation. The RFP has been approved and waiting on details of construction. Inland Development/Windwave were chosen for this project. At time waiting for legal counsel to approve paperwork. Tom McCoy asked who is paying for project?

Commissioner McCoy asked also how the cost is being split? Judge Shaffer replied there is a verbal agreement that Gilliam County will pay \$1,150,000.00 and the City of Condon will add \$480,00.00 to project. The remainder of the project costs will be split among the partners. There will be 12 pair of fiber in this project. Commissioner McCoy asked about the format of the agreement on this project and Mike Smith stated it will be the same model as the previous Sherman County Project.

Frontier TeleNet Web Site: Mike Smith reported the Frontier TeleNet Web Site is up but not complete at this time. Frontiertelenet.com is the web site address.

Frontier Sherman County Office Space: A lease for Frontier TeleNet office space in Sherman County was reviewed. Mike Smith reported the lease has been signed by Sherman County and office is up and running. Moved by Lynn Morley, seconded by Steve Shaffer to approve the office space lease with Sherman County with a \$1.00 per year rent. Motion carried with all present voting aye.

Frontier 911 Burns Tribe Update: Ryan LeBlanc of Day Wireless System stated that the goal was to get the connection to the Burns Paiute Tribe up and running by the end of the year. This goal

was met, and the connection is working fine. Day Wireless is still waiting for some mapping including phones and dispatch will start on February 2, 2018.

Wheeler County Wireless Project: Ryan LeBlanc, Day Wireless, is working on Phase 1 microwave upgrades which are 95% complete. Getting ready to move end users to the towers which should improve their service. This project is being coordinated with Rural Technology Group, who serves the area. Ryan stated they are getting the last mile to a more efficient system. There also are phone companies who are interested in serving the three-county area. A discussion followed on how Rural Technology Group (RTG) works in the three-county area. Ryan LeBlanc stated the Wheeler County Project has new generation equipment installed and suggested that Giliam and Sherman County could benefit by upgrading to this equipment.

Digital Switch New User: Mike Smith reported there is a potential new user for the Digital Switch. Mike stated he is negotiating with this potential new partner and there is a good chance they will become a Frontier TeleNet Customer. Mike has sent out an article showing another system having problems and is pleased that Frontier TeleNet does not experience the same due to having the proper equipment.

Intergovernmental Agreement with Sherman County: This has not been dealt with as legal counsel has been ill. Will be on the next agenda.

Sherman County Fiber Optic RFP Update: This has not been dealt with as legal counsel has been ill. Will be on the next agenda.

Other Items for Good of the Order: Discussion on Frontier By-Laws and designated alternate as a proxy vote. Judge Shaffer asked that minutes be sent to County Commissioners in Giliam, Sherman and Wheeler Counties.

Public Input/Comment: Mac Stinchfield inquired about the status of towers at the Cottonwood Park. Mike Smith replied that landowner contract needs to be signed. Motorola is building the equipment and the project is going forward. Mike also stated that the tower is within the "utility strip" and the Wild and Scenic River Act should not be an impact on the project. Hope to have this up and running in the next six months as emergency and internet service is necessary for the park.

Next Meeting: February 16, 2018 at Wheeler County Jeanne E. Burch Building. A work session will follow the regular meeting.

There being no further business the meeting adjourned at 11:25 A.M.

Respectfully Submitted

Jeanne E. Burch

Frontier TeleNet Staff

FRONTIER TELENET
SIGN IN SHEET
JANUARY 19, 2018
CONDON, OREGON

TODD Cox Day Wireless
Ryan LeBlanc Day Wireless
Mac Strickland Times-Journal
Rob Myers

FRONTIER TELENET BOARD OF DIRECTORS MEETING

MINUTES

FEBRUARY 16, 2018

The regular meeting of the Frontier TeleNet Board of Directors was called to order by Chairman Steve Shaffer at 10:02 AM. This meeting held in the Conference Room of the Jeanne E. Burch Building, 401 Fourth Street, Fossil, Oregon.

Board Present: Judge Steve Shaffer, Judge Gary Thompson and Judge N. Lynn Morley.

Also Present: Todd Cox and Ryan LeBlanc, Day Wireless System, Debbie Starkey, Wheeler County Commissioner, Mike McArthur, Association of Oregon Counties, Tom McCoy and Joe Dabulskis, Sherman County Commissioners, Mac Stinchfield, Times Journal Newspaper, Kathryn Greiner, City of Condon, Roberta Vandehey, Elizabeth Farrar, Rob Myers and Mike Smith, Frontier TeleNet Consultants and Jeanne Burch, Frontier TeleNet Staff. Jim Deason, Legal Counsel, appeared by telephone.

Directors Changes or Additions to Agenda: Judge Shaffer requested that the signing of the Keys Mountain FCC License Agreement be added.

Minutes: Minutes of January 19, 2018 Board of Directors Meeting reviewed. Moved by Gary Thompson, seconded by Lynn Morley to approve January 19, 2018 minutes as presented. Motion carried with all present voting aye.

Financial Statement: January 2018 financial statement reviewed. Moved by Lynn Morley, seconded by Gary Thompson to approve January financial statement as presented. Motion carried with all present voting aye. Gary Thompson requested an accounts receivable list be presented at the next meeting.

Gilliam County/City of Condon RFP Update: Judge Shaffer reported that this project is proceeding. There had been some discussion on the RFP between Gilliam County Consultant and City of Condon Consultant. Interview of applicants has occurred, and Inland Development Corporation chosen for the project. Gilliam County has requested that the City of Condon and Gilliam County each have 12 pair of fiber. At this time Judge Shaffer was not sure if the contracts would go through Frontier TeleNet. Negotiations are going on with City of Condon on Project Manager and disbursement of funds. Tom McCoy asked who will own fiber. Judge Shaffer replied that Inland Development Corporation would own the fiber and Gilliam County and City of Condon will lease from them. Jim Deason explained how the City of Condon and Gilliam County will have right of use of these fibers.

Frontier Regional 911-Burns Tribe Update: Mike Smith reported that 911 service started on February 1, 2018 with the Burns Paiute Tribe. Mike also pointed out that from now on this is a Frontier Regional 911 project. Ryan LeBlanc and Todd Cox, Day Wireless Systems, were in Burns and reported the dispatch is working fine.

Wheeler County Wireless Project: Ryan LeBlanc reported that phase one is 98% complete. Day Wireless will be working with Rural Technology Group (RTG) to migrate users to the new system. Phase two will start in about a week, if the weather cooperates. Moved by Gary Thompson, seconded by Lynn Morley to authorize Judge Shaffer to sign the FCC Licensing Application for Keys Mountain. Motion carried with all present voting aye. Consensus of Board that Judge Shaffer may sign necessary licensing papers as long as he brings it to the next regular board meeting. It was decided that in the future, Frontier TeleNet Agendas will have an IT dedicated report that will encompass all projects going on at the time.

Digital Switch: Mike Smith reported he is talking to two potential new users of the digital switch. Mike will be issuing an RFP on behalf of Frontier TeleNet to look at options. Mike also reported he would be working with Motorola on this RFP.

Cottonwood Tower: This project is still moving forward, and Mike Smith has been stopping at the park to check on progress. Equipment is being built and Mike cannot see any obstacles to stop the project from being up and running by fire season 2018. It was noted there will be an outdoor school session at the park location this summer.

Sherman County IGA: With the passing of Legal Counsel, Will Carey, this project is not completed. Jim Deason reported that work is now being done by Ruben Cleaveland of Annala, Carey, Thompson, Vankoten & Cleaveland Law Firm. Mr. Cleaveland and Jim Deason will work with Mike Smith.

Sherman County Fiber Project Update: No report

Audit Contract and Engagement Letter: Moved by Lynn Morley, seconded by Gary Thompson to approve the audit contract and engagement letter with Oster Professional CPA in a sum not to exceed \$6,880.00. Motion carried with all present voting aye.

Budget Officer: Moved by Steve Shaffer, seconded by Gary Thompson to appoint Jeanne Burch Budget Officer for the fiscal year 2018-2019 budget. Motion carried with all present voting aye.

Budget Committee: Moved by Gary Thompson, seconded by Lynn Morley to appoint budget committee members for the fiscal year 2018-2019 budget. Members will be: Steve Shaffer, Gary Thompson, Lynn Morley, Pat Shaw, Chris Humphreys and Brad Lohrey. Motion carried with all present voting aye.

Budget Calendar: Proposed Budget Calendar reviewed. Moved by Gary Thompson, seconded by Lynn Morley to approve Fiscal Year 2018-2019 Budget Calendar. Budget Committee

Meeting will be on May 18, 2018 and Budget Hearing will be June 15, 2018. Motion carried with all present voting aye.

Other Items For the Good of the Order: Recognition for services of Will Carey, Frontier TeleNet Legal Counsel, discussed. Moved by Lynn Morley, seconded by Gary Thompson to donate \$100.00 to Western Antique Aeroplane and Automobile Museum in memory of Will Carey. Motion carried with all present voting aye.

Sherman County Office: Mike Smith reported the Frontier TeleNet Office is officially open in Sherman County. Gary Thompson offered to coordinate with Mike Smith if other items are needed for this office.

Judge Thompson stated that Mid Columbia Producers was putting in a new accounting system and asked Mike Smith if Frontier was bidding on project. Mike Smith reported yes.

Mike Dabulskis asked how many of fibers Inland Development has. Jim Deason replied that it could be either 192 or 216.

Mike Dabulskis also asked for clarification on what RTG does. Ryan LeBlanc explained that they are the ISP. Frontier TeleNet is the backbone.

Roberta Vandehey asked for clarification if RTG has any of the Two Million Wheeler County Grant. The answer was no. Mrs. Vandehey also asked if internet service will be able to reach the rural area. Mike Smith said that plans are to install solar repeater sites in the future and this will help reach the rural areas of Wheeler County.

Kathryn Greiner asked if the erate from North Central Education District was less. The answer was yes. Kathryn also asked when the Sherman County RFP is going out. Mike Smith said very soon.

What is the timeline for the two county RFP. Mike Smith said it will be at least four months as looking for contractor to write proposal.

Next Meeting will be March 16, 2018 in Sherman County.

There being no further business the meeting adjourned at 11:10 AM.

Respectfully Submitted

Jeanne E. Burch

Frontier TeleNet Staff

FRONTIER TELENET
BOARD OF DIRECTORS PLANNING MEETING
FEBRUARY 16, 2018

A planning meeting of the Frontier TeleNet Board of Directors was called to order by Frontier TeleNet Chairman Judge Steve Shaffer at 11:15 AM. This meeting held in the conference room of the Jeanne E. Burch Building, 401 Fourth Street, Fossil, Oregon.

Board Members Present: Judge Steve Shaffer, Judge Gary Thompson and Judge N. Lynn Morley.

Also Present: Todd Cox and Ryan LeBlanc, Day Wireless System, Mike McArthur, Association of Oregon Counties, Tom McCoy and Joe Dabulskis, Sherman County Commissioners, Mac Stinchfield, Times Journal Newspaper, Kathryn Greiner, City of Condon, Roberta Vandehey, Elizabeth Farrar, Rob Myers and Mike Smith, Frontier TeleNet Consultants and Jeanne Burch, Frontier TeleNet Staff. Jim Deason, Legal Counsel, appeared by telephone.

Steve Shaffer announced the purpose of this meeting was to work on a Frontier TeleNet Future Plan. Steve Shaffer introduced Mike McArthur, Executive Director of Association of Oregon Counties to discuss the management study recently completed by his organization. Mike McArthur stated that he did not realize the Board had already received the AOC Report. Mike McArthur asked if it was necessary to go over the plan again and Steve Shaffer pointed out the AOC Plan had been thoroughly reviewed by Board Directors at the January meeting. Mike McArthur stated that he did not think it necessary to go over this document again. Steve Shaffer asked Mike McArthur to discuss the recommendations in the Management Plan submitted to Frontier TeleNet by Association of Oregon Counties.

Following are recommendations presented by Association of Oregon Counties Executive Director:

1. Legal Counsel Needed.
2. Recommend central capacity. At this time Frontier TeleNet has a Marketing Director and Bookkeeper. Suggested consolidating other services that counties need. Might be a Tri-County Court Issue and discussion on shared services such as Veterans, Building Codes, Mental Health and Human Resources. It would be a form of a Council of Governments.
3. Gary Thompson expressed his concern that putting everything under one umbrella creates more government. Gary Thompson agreed we do not have the capacity in the three counties. Questioned would one person be able to handle planning in the three-county area? The consensus of the group was no. Tom McCoy pointed out that Mid Columbia Council of Governments had problems once funding was not available. Commissioner McCoy stated the basic question is how do you pay for this service?

4. Consider hiring a manager for Frontier TeleNet.
5. Communications essential including maintaining a website, public notices and responding to public record requests.
6. Consider an advisory committee that would not be a board position. Gary Thompson asked if Frontier TeleNet should be privatized? Possible to contract for services needed if there was a tri-county organization that included other county functions other than telecommunications.
7. Mike McArthur stated the report speaks for itself and hopes that it will be implemented.
8. Frontier TeleNet needs a business plan and a marketing strategy.

Mike Smith read the mission statement of Frontier TeleNet:

1. To expand and enhance telecommunications capabilities for the efficient provision of local government services and educational services; and
2. To provide for the coordination and interoperability of communications services in Giliam, Sherman and Wheeler counties; and to cooperatively establish and maintain a consolidated, highly reliable system for the provision of educational services, 9-1-1, law enforcement, emergency services and other public health and safety communications services; and
3. To promote economic growth and the expansion and/or addition of business and industry both within the geographic boundaries of Giliam, Sherman and Wheeler counties; and where appropriate or in the best interests of the counties' citizens, the surrounding communities of interest through the development telecommunications infrastructure and related programs and services.

Mike pointed out explains what Frontier TeleNet does. Frontier TeleNet has one of the best communication projects in the state. The system was built from scratch by the three counties. In 2012 the Digital Switch was purchased. A very wise investment and brings in one-half million dollars per year. 911, Counties, Public Safety, Clinics and other business is a portion of who is served.

Steve Shaffer gave a brief history of the Digital Switch and pointed out that it was a wise move for the three counties to make this investment. Also created an opportunity for Jefferson County to join Frontier Regional 911, Steve Shaffer also stated that with fiber coming to the area Frontier TeleNet would be able to offer service to the private sector. Joe Dubulskis asked how much fiber in Sherman County. Mike Smith replied there are 96 count. Gary Thompson reported that the present hub is the Pittock Building in Portland. A hub is needed in Central Oregon. At present the nearest hubs, other than Pittock Building, are Salt Lake City and Seattle.

Mike McArthur reported on a bill in the legislature regarding the State of Oregon to provide services to State Agencies. This bill did not survive in the legislature.

Due to lack of population in the three-county area, Telecommunications have not shown interest in the area. Frontier TeleNet has provided this service.

Ryan LeBlanc of Day Wireless presented a list of needs and desirable upgrades:

1. Good job of increased capacity in both North and South.
2. Need a better connection from Jefferson County to Condon Dispatch.
3. The connection from Grizzly Mountain to Antelope can connect Jefferson County to Dispatch.
4. The link between Wheeler County and Antelope sites could be of advantage.
5. Public Spectrum that anyone can use is much less expensive.
6. Public Spectrum negative is anyone can put up anything at any time.
7. A dedicated license link is one that anyone can use.
8. Dedicated license link is much more expensive for is public safety secure.
9. Potential of going directly from Antelope to Day Wireless tower on Grizzly. Need to compare the costs.
10. Roosevelt needs a new roof and this can cost between \$13,000.00 to \$15,000.00. A generator is needed at this site.
11. Gilliam and Sherman Counties have old repeaters that are not supported by Motorola. Ten repeaters need to be replaced in Giliam County at the cost of \$25,000.00 per repeater. Need a planned replacement schedule. VHS is a good backup as it can go places that 700 cannot.
12. North loop microwave update. Did not include links that go across the river. Need to upgrade. There are some spare parts and 23 links need to be updated at \$6,500.00 each. Juniper Point site is full and needs a higher tower.
13. Need John Day run to serve Grant County. It needs to be licensed if used for dispatch.
14. Flock to Dayville needs to upgrade with a \$2,500.00 estimated cost. The upgrade needs immediate attention.
15. Potential to serve Harney County from Burns connection. There is a potential to connect John Day to Harney County Schools.

Mike Smith announced that he, Ryan LeBlanc and Steve Wynn are going to meet and develop a list of priority projects and costs for the Board of Directors.

Following Questions were asked:

What are Frontier TeleNet Strengths?:

1. Steve Shaffer: Our infrastructure to cover our geographic area. Being able to share service.
2. Gary Thompson: Using our model in other parts of the United States.
3. Lynn Morley: Progressive. Good Network.
4. Ryan LeBlanc: Ability of three counties to work together.

What are our challenges?:

1. Steve Shaffer: Keeping our existing business plan. Keeping up with the perception that we do not know what we are doing.
2. Gary Thompson: Perception that we are sloppily run and not professional.
3. Lyn Morley: Keeping our head above water and follow a business plan.

Whom do we serve today?:

1. Steve Shaffer: Our counties, schools and small business.
2. Mike Smith: Counties, Public Safety, Schools and Health Centers, Cell Companies, ISPs.

Who can we potentially serve?:

1. Steve Shaffer: Suppliers of the Last Mile. Other State and Local Governments.
2. Gary Thompson: No reason to not supply high-speed internet to other users. An example is Klickitat and Skamania County, Washington.
3. Mike Smith: Can do a better job of service to federal agencies.

How do we get there?

1. Steve Shaffer: Partner with other agencies. An example is Qlife, Umatilla-Morrow Radio.
2. Ryan LeBlanc: Charter Network and Zayo Bandwidth being disconnected and will save some money.
3. Joe Dabulskis: Need to let it be known how advanced the Frontier TeleNet system is.
4. Tom McCoy: Need to know what fiber is being used, what does it cost and what does it bring in.
5. Tom McCoy: Who are wireless customers and what they should have. Need a schedule.
6. Need a financial plan and how the plan can be accomplished.
7. Need erate monies.

There will be a yearly planning meeting for Frontier TeleNet and quarterly updates will be given at the Tri-County Court Meetings.

There being no further business the meeting adjourned at 12:55 PM.

Respectfully Submitted:

Jeanne E. Burch

Frontier TeleNet Staff

FRONTIER TELENET
BOARD OF DIRECTORS MEETING

MINUTES

MARCH 16, 2018

The regular meeting of the Frontier TeleNet Board of Directors called to order by Chairman Judge Steve Shaffer at 10:10 AM. This meeting held in the conference room of the OSU Extension Office, 66365 Lonerock Road, Moro, Oregon.

Directors Present: Judge Steve Shaffer, Judge Gary Thompson and Judge N. Lynn Morley.

Also Present: Ruben Cleaveland, Frontier TeleNet Attorney, Dale Scobert, City of Condon, Joe Dabulskis, Sherman County Commissioner, Brad Lohrey, Sherman County Sheriff, Tom McCoy, Sherman County Commissioner, Rob Myers, Mike Smith and Jeanne Burch, Frontier TeleNet Staff.

Minutes: Minutes of February 16, 2018 Board of Directors Meeting Reviewed. Moved by Lynn Morley, seconded by Gary Thompson to approve minutes with the correction of Joe Dabulskis name. Motion carried with all present voting aye.

Minutes of February 16, 2018 Planning Meeting reviewed. Moved by Lynn Morley, seconded by Gary Thompson to approve minutes as presented. Motion carried with all present voting aye.

Financials: Financial Report for February 2018 reviewed. Moved by Lynn Morley, seconded by Gary Thompson to approve financial recap as presented. Motion carried with all present voting aye.

Resolution No. 3/16/2018-01: Jeanne Burch explained to Directors that a resolution to move funds was necessary to comply with Oregon Budget Law. Moved by Gary Thompson, seconded by Lynn Morley to approve Resolution No. 3/16/2018-01, a resolution to transfer funds in the following amounts in the Frontier TeleNet Budget:

Account No. 516, Miscellaneous add \$10,000.00

Account No. 513, Bandwidth Expense add \$50,000.00

Account No. 520, Personal Services add \$30,000.00

Account No. 5010, Contingency deduct \$90,000.00

Motion carried with all present voting aye.

IT and System Updates and Progress Report: Mike Smith, made the following report regarding IT and Systems Items: Day Wireless System provided this report.

1. Sherman County Courthouse: Working on the wiring for Sherman County Courthouse.
2. Old Sherman County Drangonwave Link Failure. This line was a backup and has been decommissioned.
3. Wheeler County Wireless Phase II: Parts are arriving and FCC License in process. Need FCC License to proceed with the installation process.
4. Testing Microwave in Wheeler County for Spray.
5. Kent Generator: Installed and testing generator.
6. New Frontier TeleNet Office: This office has no internet. Mike will talk to Sherman County about installation.
7. The original Day Wireless Report is attached to the printed copy in the Frontier TeleNet Minutes Notebook.

Business and Marketing Report: Mike Smith presented the following report on business and marketing:

Introduced Ruben Cleaveland with Annala, Carey, Thompson, Vankoten & Cleaveland who will be the attorney taking over for Will Carey on Frontier TeleNet legal affairs. Steve Shaffer asked Mike Smith to work on a new contract with Annala, Carey, Thompson, Vankoten & Cleaveland with the passing of Attorney Will Carey.

Grant County PSAP: An offer has been received to provide Grant County with 911 Dispatch Service. A 911 Board Working Group has been organized and Lynn Morley serves on this board. A report will be presented at the April 2018 Frontier TeleNet Board of Directors Meeting on the progress of this project.

Frontier TeleNet and 911 Center: An extensive conversation was held regarding what does Frontier TeleNet get from the 911 Center. Mike Smith replied that each county receives public emergency services for police, ambulance and other services as needed. The need for a reasonable payment from Frontier Regional 911 to Frontier TeleNet was discussed and this will be presented at the Frontier Regional 911 Budget Meeting.

An IT Work Group is being formed for the services to Mid-Columbia Economic District. Frontier TeleNet is available for this project.

Working with Wasco County on an agreement for the Suefort Hill Location. This is an excellent location for Frontier TeleNet to work toward the west. This location served NORCOR in the past.

Worked on assessment of Eakin Elevator south of Grass Valley to see if it can serve as a Frontier TeleNet Site.

A Teleco has made a proposal to serve Wheeler County but wants to trade for services. No discussion by the Board on this item.

Working with Attorney Jim Deason on the Sherman County Project with the State of Oregon. The State of Oregon wants Sherman County to own the project.

Met with Wheatland Insurance Agent to be sure Frontier TeleNet equipment is adequately covered.

Working with Umatilla Radio District and Motorola.

Worked on National Interoperability Channel Survey for the State of Oregon.

Attended Sherman County Radio Users Group in Sherman County and Gilliam County. Need better radio coverage to the hospital in The Dalles for Gilliam County. Gilliam County is interested in a 700-pager demonstration that will happen next month.

Grant to Microsoft for non-line of site equipment has made it to the next round. This will benefit hard to reach areas. Also a grant has been written for Sherman County use.

Frontier TeleNet office is furnished and up and running.

Zayo Network has been disconnected from the system as it is not needed.

The website is progressing.

The written report from Mike Smith is attached to these minutes in Frontier TeleNet Minute Notebook.

Other Items for the Good of the Order:

Gary Thompson stated that since a new water system is going in at Biggs, this would be a good time to install fiber in the open trench. The answer was yes, and Mike Smith will follow up on this project.

Eakin Elevator: There is a possibility of a truck stop going in at this site and high-speed internet will be needed. Mike Smith replied that Kent has high-speed internet that can reach this site. Also, a grant has been written to connect Qlife to Maupin.

Mike also reported that Temp-Rite has renewed their maintenance agreement.

Public Input/Comment: Dale Scobert inquired about the Cottonwood Canyon Park and progress being made. Mike Smith replied that equipment is here and ready to be installed. Hope to have everything operating by summer.

Joe Dabulskis reported that the Moro Library and the SWCD are interested in internet service. Mike Smith will follow up on these items.

Next Meeting: April 20, 2018 at the Gilliam County Courthouse in Condon, Oregon.

There being no further business the meeting adjourned at 10:40 AM.

Respectfully Submitted:

Jeanne E. Burch

Frontier TeleNet Staff

Approved: *Steve Krappe*

Date: 4-20-18

FRONTIER TELENET
SIGN IN SHEET
MARCH 16, 2018
BOARD OF DIRECTORS
MEETING

<u>Name</u>	<u>Representing</u>	<u>Phone/Fax</u>	<u>E Mail</u>
Ruben Cleveland	Attorney	541-386-1811	clevelandreyclaw.ca
DALE SCOBERT	CITY OF CONDON	541-384-6111	POLICE@CITYOFCONDONOR CON
Joe Dabulski's	Sherman County	541 993 9837	JoeDab3JMIT@com
Rob Myers	Telenet	541-980-4946	rob@remyers.org
BRAD LOWREY	Sherman County	541-980-1615	Sheriff@Sherman county.net
Lynn Morley	Wheeler County	541-765-3460	lmorley@wheeler or.us
GARY THOMPSON	Shaw Co	541-565 5260	gthompson@sh
STEVE SHAFFER	Gilliam Co	541-384-6357	STEVE.SHAFFER@cgilliam

FRONTIER TELENET
BOARD OF DIRECTORS MEETING

APRIL 20, 2018

MINUTES

The regular meeting of Frontier TeleNet Board of Directors called to order at 10:07 AM. This meeting held in the courtroom of the Gilliam County Courthouse, 221 S. Oregon Street, Condon, Oregon.

Directors Present: Judge Steve Shaffer, Judge N. Lynn Morley and Commissioner Joe Dabulskis, representing Sherman County.

Also Present: Ryan LeBlanc, Steve Wynne, Justin Sterrett, Marlon Johnson, Day Wireless Systems, Shawn Halsey, Umatilla-Morrow Radio Data District, Nicole Jackson, Chris Lentz, Motorola, Mac Stinchfield, Times Journal Newspaper, Kathryn Greiner, City of Condon, Mike Smith, Rob Myers, Jeanne Burch, Frontier TeleNet.

Directors Changes or Additions to Minutes: None

Introduction of Shawn Halsey from Umatilla-Morrow Radio Data District. Mr. Halsey explained that this is a separate district and independent of county government. Interested in exploring possible partnerships with several entities.

Introduction of Chris Lentz and Nicole Jackson from Motorola. Mr. Lentz described the services Motorola provides to Frontier Telenet.

Minutes: Minutes of March 16, 2018 reviewed by Directors. A correction noted in the name of Umatilla-Morrow Radio Data District. Moved by Lynn Morley, seconded by Joe Dabulskis to approve March 16, 2018 minutes with correction. Motion carried with all present voting aye.

Finances: Financial Statement for March 2018 reviewed by Directors. It was noted that OCHIN is due but they are waiting for their current allocation to be approved. Moved by Lynn Morley, seconded by Joe Dabulskis to approve financial statement as presented. Motion carried with all present voting aye.

IT and System Update:

Steve Wynne reported the following:

1. Working on moving Sherman Fiber to 700. Pagers have arrived and more radios have been ordered. Gilliam County is doing a demonstration of 700 now.
2. Making sure that backups are working. Lost power supply at Roosevelt and there was a lengthy power outage. Microwave did not go down during this event. Asked that any

power outage notices be sent on immediately. There is a need for a generator at this site.

3. Microwave System is working solid and working on licensing for Mitchel.

Ryan LeBlanc reported following:

1. Wheeler County Wireless Project Update: Phases 4 and 5 are about to proceed. Each phase of this project will be under \$250,000.00.
2. The generator at Kent installation should be complete and gone live by this time.
3. U.S. Cellular: Circuit from Spray to Fossil may have additional costs.

Business and Marketing Report:

Mike Smith, Marketing Director reported the following:

- 1, Sherman County has signed an agreement between Sherman County and Frontier TeleNet for the line to Rufus. There will be a separate IGA on this project. There was a discussion on who pays for management. RFP and Construction Documents are going through legal review at this time. The agreement is modeled after the Wheeler County Broadband Agreement.

2. Discussion regarding Intergovernmental Agreement for implementation of Phase Three of Sherman County Broadband Project. Moved by Joe Dabulskis, seconded by Lynn Morley to approve Intergovernmental Agreement for Implementation of Phase Three of Sherman County Broadband Project with the understanding that Sherman County Court must approve. Motion carried with all present voting aye.

3. A phone outage was experienced at Frontier Regional 911 Center and Centurylink is responsible for this service. Looking for another contractor and Oregon Emergency Management will allow switching to another service. Steve Wynne is pleased with the proposed new contractor and how it is set up.

4. Applied for Mid Columbia Economic District Request for Proposal for service to all Sherman County homes. Explained how this would work and how it would be financed.

5. Request from citizen to explain what Management Resources does for Frontier TeleNet. Mike Smith explained that Management Resources contracts to handle all the Oregon Health Network allocations for Health Clinics. They do the paperwork to apply for reimbursement of costs from Oregon Health Network and also the individual clinics to pay for bandwidth service. This contract has been in place since February 5, 2011.

6. Met with John Anderson, Wheatland Insurance agent to review coverage on all Frontier TeleNet equipment and other necessary coverage.

7. Noted that the Frontier TeleNet By-Laws need to be updated and will be done with coordination of legal counsel.

8. Umatilla-Morrow Radio Data District: Meetings regarding a possible partnership with the Umatilla-Morrow Radio Data District. Discussed how this partnership might work and the updating of sites. There was a discussion on how partnerships have worked in the past and is this the right move for Frontier TeleNet. Shawn Halsey has concerns about the contract and how it would be interpreted. Umatilla-Morrow Radio Data District Board would want to avoid the legality of an ORS 190. They are not a taxing district. Shawn Halsey pointed out he could not speak for the Board. A tour of the Frontier TeleNet sites will occur next week and then a discussion will be held on the structure of a possible partnership. There might be consideration of an Advisory Board or position on the Frontier TeleNet Board. Frontier TeleNet is more than just the digital switch so that would be a consideration. There needs to be a meeting of the two boards. Joe Dabulskis asked if there is a downside to this project. Chris Lentz of Motorola stated that everyone is moving to a shared system. He can see no downside on how the system would work but governance is where the problem might be and that would need to be addressed. Mike Smith asked if there were samples of governance and several ideas were given. Mike Smith will follow up on these samples and report back to the Frontier TeleNet Board.

Joe Dabulskis asked if there was more he should know about this proposed project. Lynn Morley and Steve Shaffer both stated it was new to them also and this is the first discussion on the project so Joe has as much information as they do.

Public Comment: Kathryn Greiner asked if the Keys Mountain Agreement document presented by Day Wireless System is a different one than the monthly payment made to Day Wireless Systems for maintenance. Ryan LeBlanc answered that this is different.

The regular meeting was recessed to enter executive session:

Executive Session under ORS 192.660 (2)(g) Negotiations for Trade or Commerce called to order at 11:15 AM.

Regular Meeting resumed at 12:15 PM.

Steve Shaffer recommended there will be continued discussion with Umatilla Morrow Radio Data District and Motorola. Motorola will be tasked with cost and Shawn Halsey and Mike Smith with Governance.

Keys Mountain Agreement: Moved by Lynn Morley, seconded by Steve Shaffer to approve the Wheeler County Wireless Keys Mountain and 587 VHF Simulcast Agreement. Motion carried with Lynn Morley and Steve Shaffer voting aye and Joe Dabulskis abstaining.

Next Meeting will be May 18, 2018 in Fossil. Frontier TeleNet Budget meeting will meet at 9 AM and regular Board of Directors Meeting will start at 10 AM.

There being no further business, the meeting adjourned at 12:25 P.M.

Respectfully Submitted:

Jeanne E. Burch

Frontier TeleNet Staff

Approved: N Lynn Morley

Date: 6-7-18

N. LYNN MORLEY, VICE-CHAIR, FRONTIER TELENET

FRONTIER TELENET
BOARD OF DIRECTORS MEETING
APRIL 20, 2018
CONDON, OREGON
SIGN IN SHEET

<u>NAME</u>	<u>REPRESENTING</u>	<u>PHONE OR EMAIL (VOLUNTARY)</u>
Rob Myers	Frontiers	rob@remyers.org
Ryan LeBlanc	DWS	rleblanc@daywireless.com
Steve Wynne	DWS	swynne@daywireless.com
Mac Strickfield	Times-Journal	
Kathryn Greener	Condon	administration@cityofcondon.com
Shawn Halsey	UMRDD	shawn.halsey@umrdd.org
JUSTIN STERRETT	DAY WIRELESS	jsterrett@daywireless.com
Marlon Johnson	Day Wireless	mjohnson@daywireless.com
Nicole Jackson	Motorola	Nicole.Jackson@motorola
Chris Lentz	Motorola	solutions.com Chris.Lentz@motorolasolutions.com

FRONTIER TELENET
BOARD OF DIRECTORS MEETING

MAY 18, 2018

MINUTES

The regular Board of Directors Meeting of Frontier TeleNet was called to order by Vice-Chair Judge N. Lynn Morley at 10 AM. This meeting was held in the conference room of the Jeanne E. Burch Building, 401 Fourth Street in Fossil, Oregon.

Directors Present: Judge N. Lynn Morley and Judge Gary Thompson.

Also Present: Steve Wynn and Ryan LeBlanc, Day Wireless Systems, Rob Ordway, Wheeler County Commissioner, Roberta Vandehey, Mike Smith, Rob Myers and Jeanne Burch, Frontier TeleNet Staff.

Directors Changes or Additions: None

Minutes: Moved by Gary Thompson, seconded by Lynn Morley to approve minutes of April 20, 2018 Board of Directors Meeting. Motion carried with all present voting aye.

Financial Statement: Finance Statement for April 2018 reviewed by Directors. Moved by Gary Thompson, seconded by Lynn Morley to approve finance statement as presented. Motion carried with all present voting aye.

IT Systems Updates:

Steve Wynn of Day Wireless reported that he has been doing a lot of updates on the backup system. There was a problem with backup at the Erskine site. Hire Electric is working on a quote to service UPS. There was a discussion about new battery technology which may need to take place in the future. A Controller Board need to be replaced in the digital switch. This was taken care of overnight by Motorola and there was no loss of data or downtime. Monitor is working well.

Ryan LeBlanc of Day Wireless System reported that he has been working on GOBHI Clinic. He is changing the way they use circuits. Frontier TeleNet will be able to cancel service with Charter Communications. Wright Chevrolet is working properly. Wheeler County Broadband Project is progressing in phase two. The link should be upgraded soon, and Ryan will be working with Rural Technology Group (RTG) to change their settings to the new system.

Business and Marketing Report:

Mike Smith reported that the Intergovernmental Agreement with Sherman County for Phase Three of the fiber project has been approved. An RFP has been issued with Mid-Columbia Economic Development for a project that will provide fiber to each home in Sherman County

cities. ORTELCO has shown an interest in providing wireless internet in the area. Mike attended the Condon Broadband Meeting and made a presentation on what Frontier TeleNet does and what it can provide. Working with Grass Valley Grocery Store to provide internet service. Talked to representative of FirstNet and AT&T about Frontier TeleNet providing backhaul. Working with T-Mobile about providing backhaul for Mitchell site. Contacted Frontier TeleNet Web Site provided about corrections and additions. These are being taken care of. Discussed an article in the Times Journal that indicated Directors did not know about discussion with Umatilla Morrow Radio Data District. Mike stated he felt that was not the case and Lynn Morley disagreed.

Umatilla Morrow Radio Data District: Mike reported that he and a representative of Umatilla Morrow Radio District had looked at multiple sites but had given a negative report back on their observations. They were particularly upset about weeds and proper fencing. Mike Smith felt that the "state of the art" equipment was not taken into considerations. Steve Wynn stated that even though the report was negative, some observations were legitimate. Weeds and fencing have been a problem and sometimes at co-locations, users sometimes do not install equipment in a proper manner. Gary Thompson asked about generator in Sherman County and if it can be used. Mike discussing with Sherman County Emergency Service Director. The Board of Directors need to decide what findings from this tour need to be taken care of. A discussion was held on the Motorola Service Agreement and why they were able to provide a revision for the Umatilla Morrow Radio District Project. Currently Umatilla Morrow Radio Data District is looking for other providers.

Cottonwood Park Project: There was a site visit at Cottonwood and a NEPA study is in progress. State of Oregon feels they will need 200 MG of service.

Grant County: Still working on this project for service with Frontier Regional 911.

Another County is considering 911 Service. Mike will report on this at a future meeting.

Other Items for Good of the Order:

Gary Thompson reported he is working on an Opportunity Zone for Sherman County. This zone forgives the capital gain tax. A firm representing solar farms is interested in putting in a refurbished site at Biggs at industrial site.

Public Comment: None

Next meeting June 15, 2018 in Moro. (Note: After this meeting the next meeting date was changed to June 29, 2018 in Moro.)

There being no further business the meeting adjourned at 11:05 AM.

Respectfully Submitted: Jeanne E. Burch, Frontier TeleNet Staff

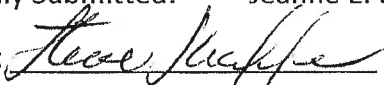
Approved:  Judge Steve Shaffer June 29, 2018

FRONTIER TELENET
BOARD OF DIRECTORS MEETING
MAY 18, 2018
WHEELER COUNTY
SIGN IN SHEET

<u>NAME</u>	<u>REPRESENTING</u>	<u>EMAIL OR PHONE</u>
Robert Vandenberg		541-468-2425
Robert L. Cardigan	Wheeler County	541-420-4375

FRONTIER TELENET
BOARD OF DIRECTORS MEETING
JUNE 29, 2018
MINUTES

The regular meeting of the Frontier TeleNet Board of Directors was called to order by chairman Judge Steve Shaffer at 10:05 A.M. This meeting held in the OSU Extension Office Conference Room, 66365 Lonerock Road, Moro, Oregon.

Directors Present: Judge Steve Shaffer, Judge Gary Thompson and Judge N. Lynn Morley

Also Present: Todd Cox, Ryan LeBlanc and Steve Wynne, Day Wireless Systems. Mac Stinchfield, Times Journal Newspaper, Mike Smith, Rob Myers and Jeanne Burch, Frontier TeleNet Staff.

Budget Hearing:

The Budget Hearing for the Frontier TeleNet Fiscal Year 2018-2019 was opened at 10:25 AM. There was no public input. The Budget Hearing closed at 10:27 AM.

Regular Session resumed at 10:28 AM.

Resolution No. 6/29.2018-003, A Resolution Adopting the Frontier TeleNet Budget reviewed.

Moved by Lynn Morley, seconded by Gary Thompson that the Frontier TeleNet Budget for Fiscal Year 2018-2019 is approved in the amount of \$4,630,603.00 and the funds are appropriated.

Motion carried with all present voting aye.

Minutes: Moved by Gary Thompson, seconded by Lynn Morley that minutes of May 18, 2018 be approved as presented. Motion carried with all present voting aye.

Financial Review:

Moved by Lynn Morley, seconded by Steve Shaffer that financial report for May 2018 be approved as presented. Motion carried with all present voting aye.

Resolution Transferring Funds: Jeanne Burch reviewed certain line items that had gone over in the current budget. Moved by Lynn Morley, seconded by Steve Shaffer that Resolution No. 6/29/2018-002 be approved making the following budget adjustments:

Account 506-Electricity Other-Add \$200.00

Account 508-Insurance-Add \$2,000.00

Account 512-Legal-Add \$2,000.00

Account 513-Bandwidth-Add \$42,000.00

Account 516-Miscellaneous-Add \$10,000.00

Account 520-Personal Services-Add \$26,000.00

Account 537-Rental Expense-Add \$1,500.00

Account 5010 Contingency-Deduct \$83,700.00

Motion carried with all present voting aye.

IT and Systems Updates Progress Report:

Ryan LeBlanc of Day Wireless System reported that Wheeler Broadband was progressing on schedule. RTG is ready to transfer their customers to the new system. That will be RTG responsibility after initial testing. That cap that was placed on Mitchell while construction was being finished has been removed. Mike Smith stated that multiple vendors can now use the system.

Black Rock Grazing Site was discussed. It was noted that underground electricity is a requirement at this site. This site is used for redundancy.

Madras Power supply in server failed during a storm. There was no loss to customers and the redundant servers work very well. Frontier Regional 911 was able to keep operating using the Wheeler Broadband System. The technicians were very pleased to see the system work so well for emergency services.. Sherman County has also experienced several fires this month and most of the county was covered by the system. There has been a microwave problem at the Spray Clinic and Day Wireless is working on this problem.

Security at Sites: There is a need to secure site at AirBase. Rob Myers has taken care of weed-eating and Don Farrar has sprayed. A chain-link fence is needed and site needs to be leveled and rock installed. Moved by Lynn Morley, seconded by Gary Thompson to approve Ron Mobley building a 6-foot chain-link fence at AirBase in the sum of \$8,390.00. Rock and Site Preparation to be determined, not to exceed \$10,000.00. Motion carried with all present voting aye.

Secondary HVAC at Kahler Basin needs replacing. Moved by Gary Thompson, seconded by Lynn Morley to approve Secondary HVAC at Kahler Basin in the amount of \$5,620.00. Motion carried with all present voting aye.

Business and Marketing Report:

Mike Smith gave the following progress report:

1. Working with T-Mobile in Mitchell. They want to buy service from Frontier TeleNet but they have some questions about Microwave.

2. Discussed with a cell phone company the use of fiber in Sherman County.
3. Mid-Columbia Economic Development District on behalf of Sherman Cities awarded RFP to Gorge Net. Gorge Net is interested in purchasing bandwidth from Frontier TeleNet.
4. Grass Valley Grocery Store now has wireless service.
5. Partnering on Sherman County Projects. Conduit is going in for free at Biggs Junction.
6. Update on Umatilla-Morrow Radio District. Not going forward with Frontier TeleNet as they are concerned about Frontier TeleNet not maintaining sites with fencing and rock.
7. Another County is interested in using Digital Switch.
8. Another County is interested in services from Frontier Regional 911.
9. Cottonwood State Park: NEPA Work is being done. Moved by Gary Thompson, seconded by Lynn Morley to approve \$14,100.00 for NEPA Study at Cottonwood State Park. Pending Legal Counsel written approval. Motion carried with all present voting aye.
10. Cottonwood State Park Tower RFP: Moved by Gary Thompson, seconded by Lynn Morley to accept the quote from Windwave, as contractor of record and responsible contractor, in the sum of \$99,500.00. Pending Legal Counsel written approval. Motion carried with all present voting aye.
11. A company outside Spray needs improved communication. Day Wireless will work with them.
12. Work with RTG on improving speeds.
13. Mike Smith is working with ORTELCO regarding Wheeler County Projects.
14. Working on RFP for fiber build from Wasco to Rufus.

Other Items for The Good of the Order:

Steve Shaffer spoke on the need for Frontier TeleNet to take a good hard look at how business is done. Feels we need to separate internet service and public safety. Future looks bleak and e-rate is becoming competitive. Steve Shaffer feels that revenue is dwindling and need to take a hard look at structure and pricing. 5G Technology is in the near future and Frontier TeleNet needs to be organized. Steve Wynne pointed out that not all the towers are capable of supporting carrier information.

Mike Smith responded that Frontier TeleNet is in a good position to meet the future with the Frontier TeleNet infrastructure. Ryan LeBlanc of Day Wireless stated that they would be available to go to meetings if technical support is needed.

Steve Shaffer gave a brief update on the Condon Fiber Project. Presently working on right-of-way issues with Inland Development Corporation and a third party. Zayo is working on the expansion of their system. Gilliam County and City of Condon each have 12 pairs of fiber.

Next Meeting of Frontier TeleNet will be July 20, 2018 at Gilliam County Courthouse in Condon, Oregon.

There being no further business, the meeting adjourned at 11:50 AM.

Respectfully Submitted:

Jeanne Burch, Frontier TeleNet Staff

Approved: July 20, 2018

A handwritten signature in cursive script, appearing to read "Steve Shaffer". The signature is written in black ink and is positioned above the printed name.

STEVE SHAFFER, FRONTIER TELENET CHAIRMAN

FRONTIER TELENET
BOARD OF DIRECTORS MEETING
June 29, 2018
SHERMAN COUNTY
SIGN IN SHEET

<u>NAME</u>	<u>REPRESENTING</u>	<u>EMAIL OR PHONE</u>
Gary Thompson	Sherman Co	
Lynn Morley	Wheeler Co,	
Steve Wynne	Day Wireless	
Ryan LeBlanc	Day Wireless	
Rob Myers	Frontier TeleNet	
TODD Cox	Day Wireless	
Mike Smith	FTN	